

SALCO PRODUCTS
 PART# TC20NGPEP
 MATERIAL: EPDM PC
 PATENTS:
WWW.SALCOPRODUCTS.COM/LEGAL

SECTION A-A
SCALE 3 : 1

NOTE:
MATERIAL IS PURPLE EPDM PEROXIDE CURED DURO 75±5 SHORE A

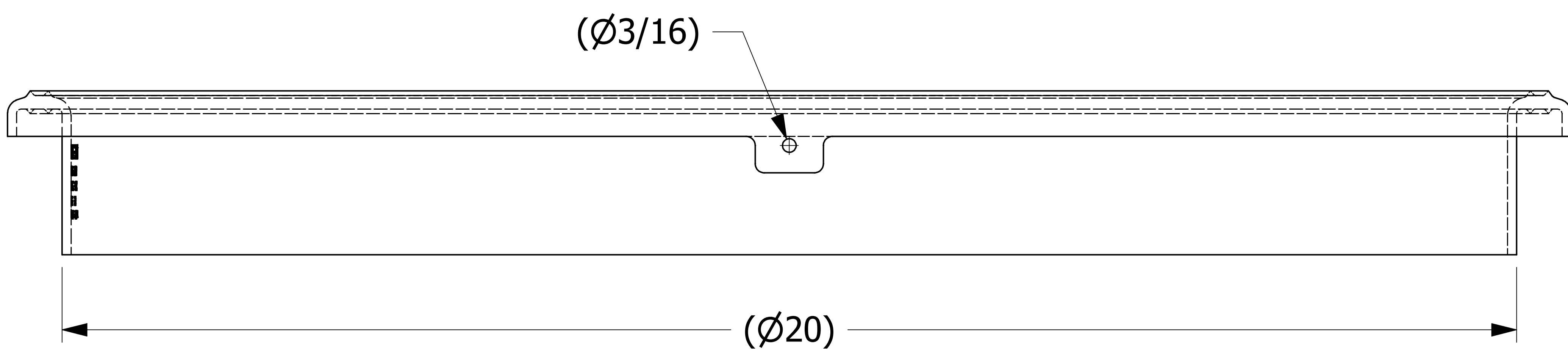

REV	BY	DATE	DESCRIPTION
T	WEB	12-15-15	UPDATED PATENT INFO
S	CHL	11-14-11	UPDATED DIMS IN SECTION B-B
R	REH	11-23-10	ADDED PATENT PENDING NOTE
Q	CHL	1-5-10	ADDED TOLERANCE TO 80° DIM
P	CHL	1-4-10	ADDED CHEVRONS TO UNDERSIDE OF GASKET
O	BRG	12-14-07	REMOVED CHART

<small>UNLESS OTHERWISE SPECIFIED DIMENSIONAL TOLERANCES FRACTIONAL: ±1/16 X.XX: ±.03 X.XXX: ±.015 ANGULAR: ±1° DEBURR ALL SHARP EDGES. ALL MACHINED SURFACES TO HAVE A 125 RMS FINISH UNLESS NOTED OTHERWISE. THIRD ANGLE PROJECTION</small>	DRAWN BY:	CLH
	CHECKED BY:	AVD
	PROTOTYPE BY:	CLH
	PROTOTYPE DATE:	2/13/1995
	APPROVED FOR PRODUCTION BY:	CLH
	PRODUCTION DATE:	1/15/1997

PART NAME: NOZZLE GASKET 20"		
MATERIAL: SEE NOTE		
PROJECT #:	961102	SHEET #:
		1 OF 1
DRAWING #:	E24481	SCALE:
		1:1
PART #:	TC20NGPEP	